

Coffee Roaster Two Pound Model (CR2) Pre-2014

User's Manual Model 2100, 2200, 2300, 2400



**Coffee Kinetics, LLC.
www.Sonofresco.com**

Patent Pending

This Manual Must Be Retained For Future Reference

WARNING

IF YOU SMELL GAS, TURN OFF THE MANUAL SHUT-OFF VALVE FROM THE PROPANE (LP) OR NATURAL GAS (NG) SUPPLY. DISCONNECT THE ELECTRICAL POWER TO THE APPLIANCE. CALL YOUR LOCAL GAS SERVICE COMPANY TO CHECK THE GAS CONNECTION TO YOUR APPLIANCE.

This WARNING is to be posted in a prominent location close to the appliance.

FOR YOUR SAFETY

DO NOT STORE OR USE GASOLINE OR OTHER FLAMMABLE VAPORS OR LIQUIDS IN THE VICINITY OF THIS OR ANY OTHER APPLIANCE.

WARNING

ELECTRICAL GROUNDING INSTRUCTIONS

THIS APPLIANCE IS EQUIPPED WITH A THREE-PRONG (GROUNDING) PLUG FOR YOUR PROTECTION AGAINST SHOCK HAZARD AND SHOULD BE PLUGGED DIRECTLY INTO A PROPERLY GROUNDED THREE-PRONG RECEPTACLE. DO NOT CUT OR REMOVE THE GROUNDING PRONG FROM THIS PLUG. ELECTRICAL GROUNDING MUST BE IN ACCORDANCE WITH THE LOCAL CODES OR IN THE ABSENCE OF LOCAL CODES WITH THE NATIONAL ELECTRICAL CODE, ANSI/NFPA 70 OR THE CANADIAN ELECTRICAL CODE, CSA C22.2 AS APPLICABLE.

WARNING

KEEP THE AREA AROUND THE APPLIANCE FREE AND CLEAR FROM COMBUSTIBLE MATERIALS. MINIMUM CLEARANCE TO ADJACENT COMBUSTIBLES SHALL BE 3 INCHES FROM THE SIDE AND BACK OF THE APPLIANCE.

WARNING

THIS APPLIANCE REQUIRES SUFFICIENT AIR FOR COMBUSTION, ROASTING AND VENTILATION. DO NOT OBSTRUCT THE FLOW OF AIR TO THE BACK VENTILATION PANEL.

AVERTISSEMENT

UNE INSTALLATION, UN AJUSTEMENT, UNE ALTERATION, UN SERVICE OU UN ENTRETIEN NON CONFORME AUX NORMES PEUT CAUSER DES DOMMAGES A LA PROPRIETE DES BLESSURES OU LA MORT. LIREZ ATTENTIVEMENT LES DIRECTIVES D'INSTALLATION OU L'ENTRETIEN DE CET EQUIPEMENT.

AVERTISSEMENT

DIRECTIVES POUR LA PRISE DE COURANT ÉLECTRIQUE
CET APPAREIL EST MUNI D'UNE FICHE A TROIS BRANCHES (PRISE DE COURANT) AFIN DE VOUS PROTEGER DES CHOCS ET DOIT ETRE BRANCHE; DIRECTEMENT DANS UN RECEPTACLE ADEQUAT DE PRISE DE COURANT A TROIS BRANCHES. IL NE FAUT PAS COUPER OU ENLEVER UNE BRANCHE DE CETTE FICHE.

ANSI Z83.11b-2009 CGA 1.8b-2009 MANAGER SERVICE EQUIPE

DESTINE; A UN USAGE AUTRE QUE DOMESTIQUE

INSTALLATION

INSTALLATION OF THIS APPLIANCE MUST CONFORM TO LOCAL CODES. IN THE ABSENCE OF LOCAL APPLICABLE CODES IT MUST COMPLY WITH THE NATIONAL FUEL GAS CODE, ANSI Z223.1, NATIONAL GAS INSTALLATION CODE, CAN/CGA-B149.1, OR THE PROPANE INSTALLATION CODE, CA/CGA-B149.2, AS APPLICABLE, INCLUDING:

- THE APPLIANCE MUST BE ISOLATED FROM THE GAS SUPPLY SYSTEM WITH AN INDIVIDUAL MANUAL GAS SHUT-OFF VALVE.
- THE APPLIANCE AND ITS INDIVIDUAL SHUT-OFF VALVE MUST BE DISCONNECTED FROM THE GAS SUPPLY SYSTEM DURING ANY PRESSURE TESTING GAS SUPPLY SYSTEM AT TEST PRESSURES IN EXCESS OF 0.5 PSI. (3.45 kPa).
- THE APPLIANCE MUST BE ISOLATED FROM THE GAS SUPPLY BY CLOSING ITS INDIVIDUAL MANUAL SHUT-OFF VALVE DURING ANY PRESSURE TESTING OF THE GAS SUPPLY PIPING SYSTEM AT TEST PRESSURES EQUAL TO OR LESS THAN 0.5 PSI (3.45 kPa).

OPERATION

SOME UNUSUAL CONDITIONS, SUCH AS NOT CLEANING THE CHAFF COLLECTOR AFTER EACH ROAST, DRASTICALLY OVERFILLING THE ROAST CHAMBER, OR BLOCKING THE ROASTER VENT, CAN CAUSE A FIRE IN THE ROASTING CHAMBER. DO NOT LEAVE THE ROASTER TO RUN UNATTENDED. IN THE EVENT OF A FIRE, TURN OFF THE GAS SUPPLY AND ELECTRIC POWER AND ALLOW THE ROASTER TO COOL COMPLETELY BEFORE TOUCHING IT.

TO REDUCE THE RISK OF FIRE OR ELECTRICAL SHOCK, DO NOT EXPOSE YOUR ROASTER TO RAIN OR MOISTURE.

DO NOT REMOVE THE HOUSING COVER FROM THE ROASTER. THERE ARE NO USER SERVICEABLE PARTS INSIDE. REFER SERVICING TO QUALIFIED SERVICE PERSONNEL.

THIS IS A GAS FIRED APPLIANCE AND MUST NOT BE VENTED INTO A CLOSED SPACE. REFER TO THE INSTALLATION PORTION OF THIS MANUAL FOR PROPER VENTING.

THE GLASS ROASTING CHAMBER AND THE METAL ABOVE THE ROASTING CHAMBER CAN CAUSE BURNS IF TOUCHED DURING THE ROASTING CYCLE.

ROASTERS IDENTIFIED FOR USE WITH NATURAL GAS MUST NOT BE RUN ON PROPANE (LP). DOING SO WOULD POSE A SERIOUS POTENTIAL FIRE HAZARD. BE SURE THAT YOU DO NOT USE A GAS OTHER THAN THE ONE SPECIFIED ON THE NAME-PLATE OF YOUR ROASTER.

ROASTER MANUAL

Roasting with Sonofresco Commercial Coffee Roaster allows you to offer a high quality product and display a truly unique feature to your customers. The Sonofresco roaster is an automatic hot air roaster designed to evenly heat coffee beans in a roasting chamber, monitor the roasting process, roast to a desired “roast level”, and cool the roasted coffee beans all in a seventeen to twenty minute cycle, depending on the degree of darkness of the roasted coffee. Although the roaster is automatic, there are procedures involved for proper operation and maintenance. Every user must learn how to correctly operate and maintain the coffee roaster to ensure consistent roasting results.

The information in this manual will prepare you to operate and maintain the coffee roaster and is covered in the following sections:

TABLE OF CONTENT

	Page
1. Introduction	6
2. Installation and Accessories	7
3. Green Coffee	10
4. Things to Remember	10
5. Filling The Roaster and Component Assembly	12
6. Control Board Functions	14
7. The Roasting Process	16
8. Coffee Basics	17
9. Preparing for the Next Roast	18
10. Detailed Chaff Screen Cleaning	20
11. Roast Chamber Maintenance	19
12. Daily Maintenance	23
13. Error Codes and Troubleshooting	26
14. Troubleshooting	23
15. Hints and Tips	27
16. Warranty Information	29
17. Return Policy	30
18. Specifications	31

1. Introduction

Welcome to the world of truly fresh coffee. With your Sonofresco coffee roaster, truly fresh roasted coffee will soon be a regular part of your life. The Sonofresco Coffee Roaster will dramatically demonstrate your commitment to freshness and quality of your end product. Your customers will soon experience the freshest coffee they have ever tasted.

We are excited about bringing the producers and consumers of roasted coffee closer together, and restoring the idea of coffee as a locally roasted, and impeccably fresh product.

Depending on the degree of darkness of the roasted coffee and the type of green coffee bean, it should take between seventeen and twenty minutes to roast and cool two pounds of coffee. In a ten hour day, you can easily roast fifty five to sixty pounds of high quality coffee with just one of Sonofresco Coffee Roaster. (Allow the coffee to sit for 48 to 72 hours before grinding and brewing, to allow the flavor to fully develop.)

Three important points to keep in mind:

1. Roasted coffee loses its freshly roasted flavor in about a week, so it is very important to keep track of the age of your roasted coffee. If you are going to sell whole bean coffee, put the “date roasted” right on the bag! Sell it or brew it within a few days of roasting, and the flavor will be genuinely memorable.
2. Always use top quality coffee. You will get better roast consistency, produce less smoke, and get much better flavor out of clean, well-graded, specialty coffees. The difference in price between top quality specialty green coffee and lower quality coffee is definitely not worth the disappointment. Please contact Sonofresco for help in selecting the perfect green coffee bean.
3. Great fresh roasted coffee can be ruined by poor grinding and brewing. Our representatives will be glad to help if you have questions about your brewing equipment or practices.

2. Installation and Accessories

Before installing the coffee roaster, unpack the appliance and read the installation and operation manual.

Locations For your Roaster - Basic Requirements We believe the roaster will prove most valuable to your business if its located where your customers can see it in operation. You may or may not be able to do that, but there are a few essential requirements for the installation of the roaster.

- A. The roaster is not water resistant and should be protected from moisture and wind.
- B. The roaster must be installed not less than three inches from combustibles. The back panel must be free of obstructions to allow for adequate air flow
- C. The roaster must be vented to the outside if installed indoors. See the section on venting options.
- D. It must be reasonably level to operate properly.
- E. If you are at an altitude at or above 4500' please let us know, some adjustments may be needed to allow the roaster to operate properly at altitudes above 4500'.

Fuel Supply:

The gas supply should be installed, adjusted, and tested by a qualified gas installer.

Propane (L.P.): The LP connection on the back of the roaster is a standard 3/8 inch male flare fitting. **(It is not necessary to use pipe sealant or tape on the flare fitting threads; doing so may cause a leak.)** The roaster is supplied with a regulator/hose assembly for connection to a standard barbeque size propane bottle with a manual shut-off valve. If connecting to a large residential size tank, the supplied propane regulator will not be needed, but the propane supply pressure to the roaster must be adjusted to a minimum of 11 inches water column for the roaster to work properly. A manual gas shut-off valve must be installed at the roaster. If you are using a propane roaster indoors, you must comply with any local codes for installing, plumbing, and venting a propane appliance.

DO NOT INSTALL THE PROPANE BOTTLE INDOORS; THE BOTTLE MUST BE INSTALLED OUTSIDE ACCORDING TO LOCAL CODES.

Natural Gas (N.G.): The natural gas roaster is supplied with a 1/2 inch male NPT fitting for connection to a natural gas supply. Installation and connection to a natural gas line must comply with any local codes. The natural gas supply pressure should be adjusted to a minimum of 7 inches water column flowing, or operating pressure, for the roaster to work properly. A manual gas shut-off valve must be installed at the roaster.

Electric Power: The roaster must be plugged into a properly wired, grounded, three prong outlet. The roaster only draws 3 amps at 120 volts ac and will not need a dedicated circuit (Note: In some commercial applications a dedicated circuit may be needed if large or multiple commercial appliances are on the same circuit. These types appliances may cause electrical noise that can cause problems with the electronic control.) Do not operate a 120 volt 60Hz appliance on 240 volts 50Hz and vice versa.

Any electrical work should be done by a qualified electrician.

Venting: The roaster must be vented to the outside when used indoors to prevent the accumulation of emissions within the dwelling. Venting options include placing the roaster under an existing exhaust hood such as in a commercial kitchen, venting directly into a steel vent pipe, or the Sonofresco vent hood. We recommend the dedicated vent hood shown in Figure 1. The vent hood will allow the roaster to be vented greater distances and will eliminate the possibility of back pressure and wind affecting the roaster associated with direct venting.

Direct Venting

Direct venting is a means of venting the coffee roaster through a ridged vent pipe system to the outside. The Sonofresco direct vent kit is supplied with everything needed for a basic installation.

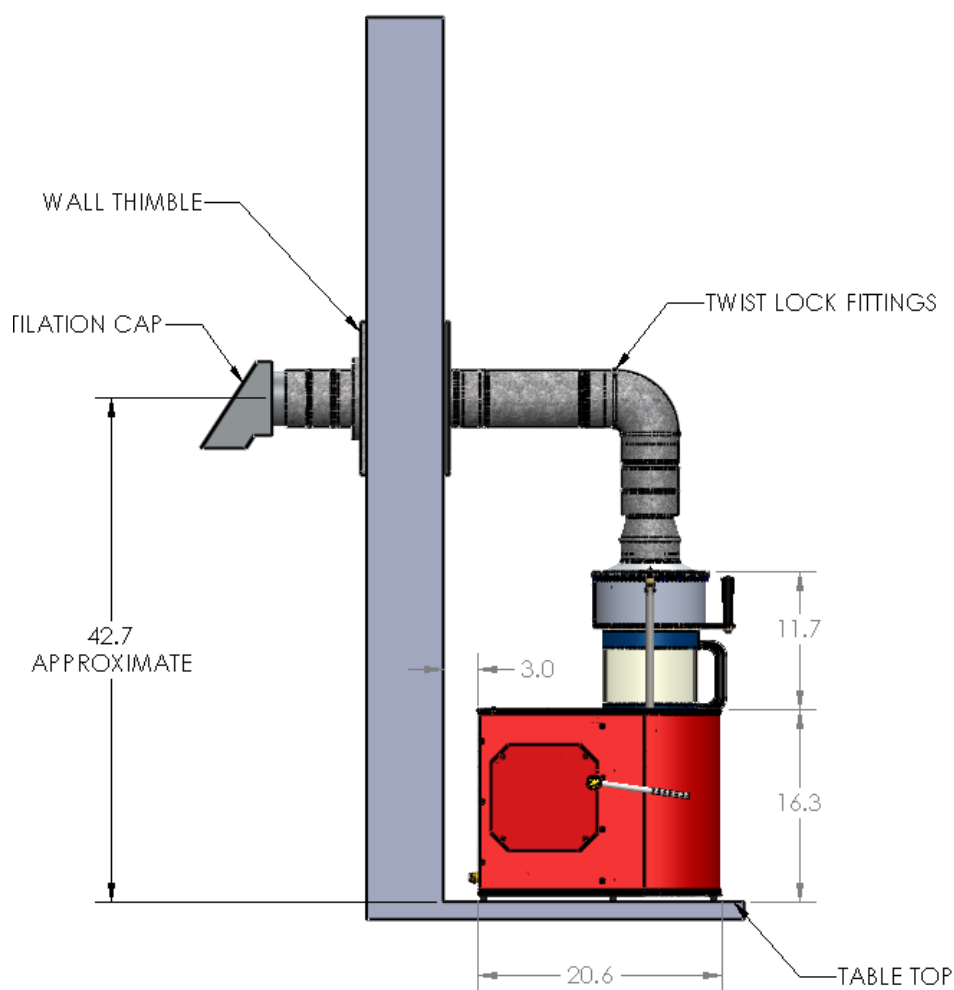

TYPICAL DIRECT VENT INSTALLATION
SONOFRESCO VK-100 VENT KIT SHOWN
ROASTER WIDTH APPROX. 13.5" WIDE

VENT HOOD

A vent hood can be ordered from Sonofresco and provides many advantages. First, since it is a powered vent, the exhaust can be vented at greater distances without the risk of back-pressure into the roaster. Second, the exhaust can be tied into existing ducting without back-pressure issues, and third, strong wind pressure against the outside vent will not pose a problem to the roaster. The Sonofresco Vent Hood also incorporates a halogen light aimed at the roast chamber, to highlight the roasting process. The basic hood installation is shown below.

Please contact Sonofresco for more details on venting the coffee roaster with a vent hood.

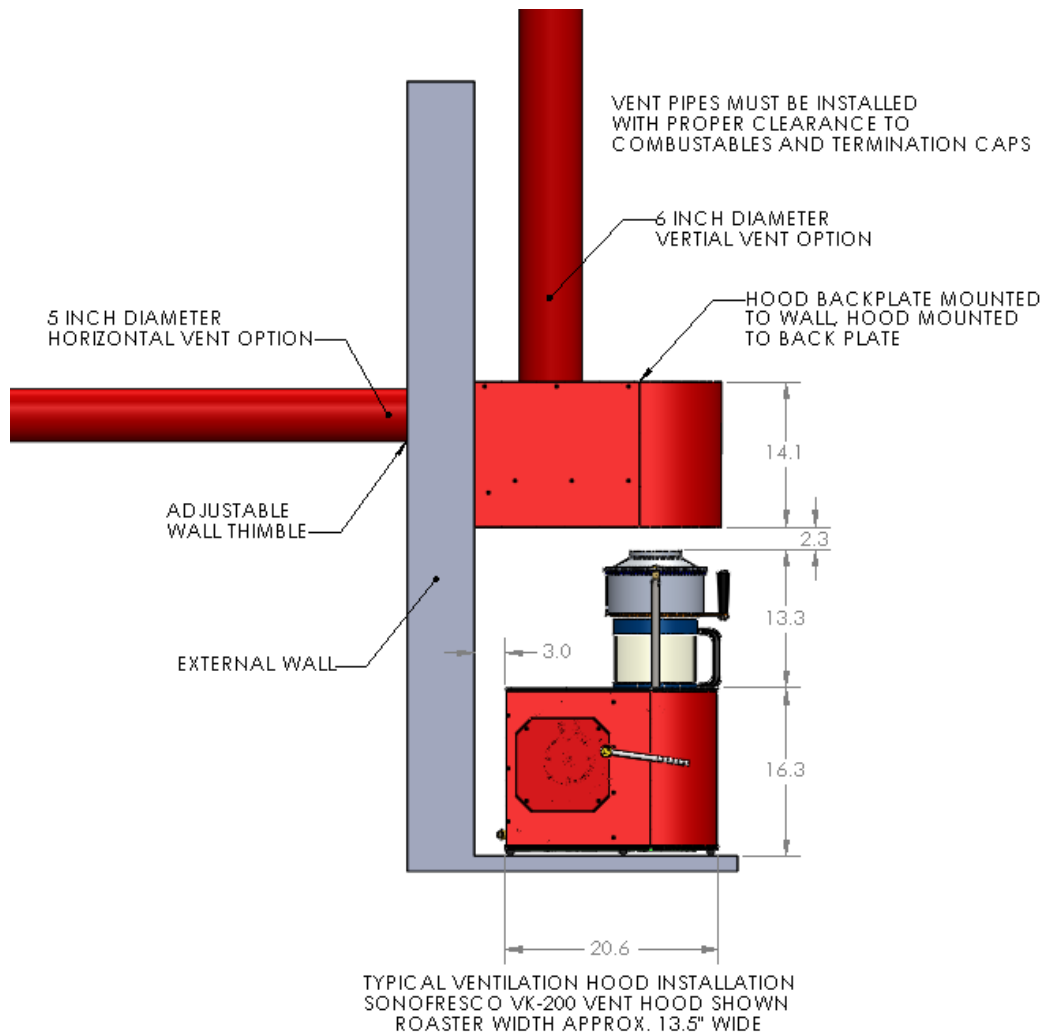

3. Green Coffee

It is important to know that not all green coffees are equal. While most green coffee will roast well in your roaster, some poorly processed coffees will not. Sonofresco maintains a good variety of excellent specialty green coffees that have been tested for suitability for our roaster. Please contact us for more information.

The roaster is designed to roast normally processed (washed or dry-process) coffees, which produce a certain amount of chaff towards the end of the roasting cycle. Decaffeinated coffees, which have no chaff, should roast fine in the roaster. But, If you are having problems roasting decaffeinated coffees, contact us and we will help guide you in the right direction.

4. Things To Remember

The coffee roaster has been designed to be simple to operate, but before you start, you must understand some basic principles of operation.

- **Do not use the power button to stop a roast.** If a roast appears to be going too dark, just turn off the “Gas” switch, located on the control board, and the roaster will begin its normal cooling cycle. Turning off the “power” switch will prevent the beans from cooling, and will begin to smolder and generate smoke. **Always allow the roasted beans to cool before removing from the roaster.**
- **Always use the measuring can supplied with the roaster.** Fill **two** cans, level to the top, with green beans . Two full cans contains approximately 2.8 pounds of green coffee and will yield approximately 2.4 pounds of coffee roasted on a #5 setting. **Do not overfill, under fill, or use a can other than the one supplied with the roaster. Doing so will cause inconsistent results and loss of coffee.** Please contact customer service for a replacement can if lost.
- **Keep the roaster clean.** Refer to the **Roaster Maintenance section** for proper cleaning procedures. It is important to maintain the roaster to keep it operating at its best.
- **Do not leave the roaster to run completely unattended.** As with any appliance, unusual conditions such as a power outage, blocked vent, or failure to properly maintain the roaster can cause coffee to smolder and generate smoke in the roast chamber. It is good practice to be within earshot of the roaster when in operation so you can respond if any of these conditions should occur.
- **Be careful not to chip or scratch the glass roasting chamber.** The roasting chamber is made of very high quality ceramic glass which is capable of handling thermal stress greater than that produced by the roaster. The glass will not however handle thermal cycles after being damaged due to impact or abrasion. The roasting chamber must be handled with care at all times. **Sonofresco will not be held liable for breakage.**

ROASTER COMPONENT DESCRIPTIONS

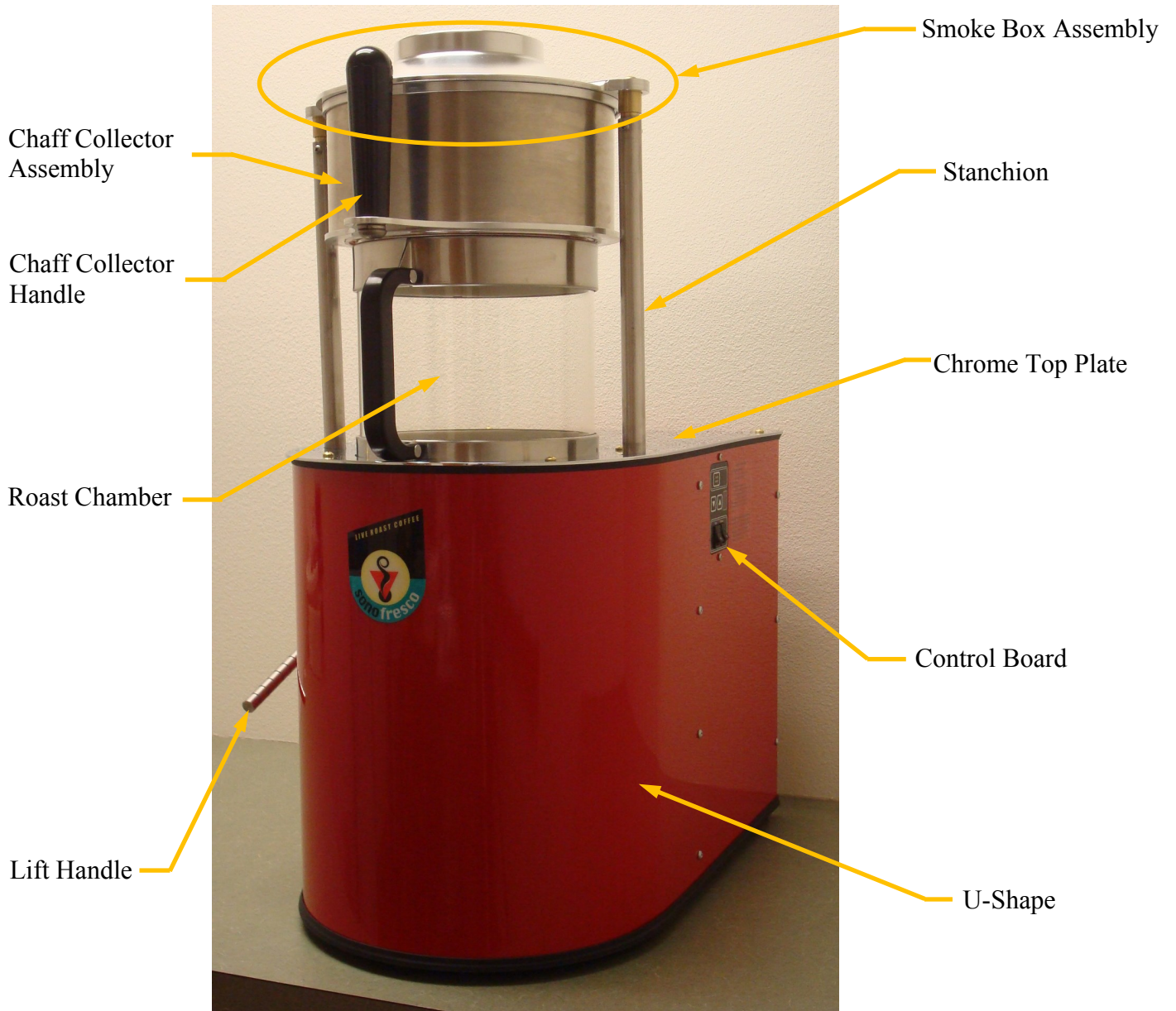

Two Pound Coffee Roaster CR2



Chaff Collector Assembly

5. Filling The Roaster and Component Assembly

Remove Roast Chamber/Chaff Collector Assembly

- Lift handle to raise smoke box assembly. (The smoke box will rise approximately 3/4".)
- Remove roast chamber/chaff collector by lifting straight up and back.

Caution: The roast chamber is able to withstand much higher temperatures than the roaster is capable of producing. However, it can be damaged if impact occurs on a hard surface and then subsequently heated during a roast.

Lift handle



The roaster is designed to operate correctly with a fixed volume of approximately 2.8 lbs. of green beans in the roast chamber and is easily measured using the supplied metal can. This volume ensures correct air flow balance through out the entire roasting process. The following steps will ensure that the correct volume of coffee beans are used for each roast.

- Fill the supplied measuring can level to the top. **Two** cans of coffee beans are used for the two pound roaster per roast cycle.
- Empty **two** level filled cans into roast chamber.

Caution: The supplied can must be used in order to achieve the correct volume of beans.



Assemble the Chaff Collector

After adding the correct volume of beans to the roast chamber, assemble the chaff collector and place it on the roast chamber. The chaff wall ends seal to the chaff collector base and screen grooves to prevent air and chaff from escaping from the roaster. The completed chaff collector assembly then seals to the top rim of the roast chamber.

- Set one of the chaff wall ends into the chaff collector groove.
- Set the chaff screen groove onto the end of the chaff wall.
- Place the chaff collector assembly on top of the roast chamber ensuring that the rubber seal seats against the top rim of the roast chamber.

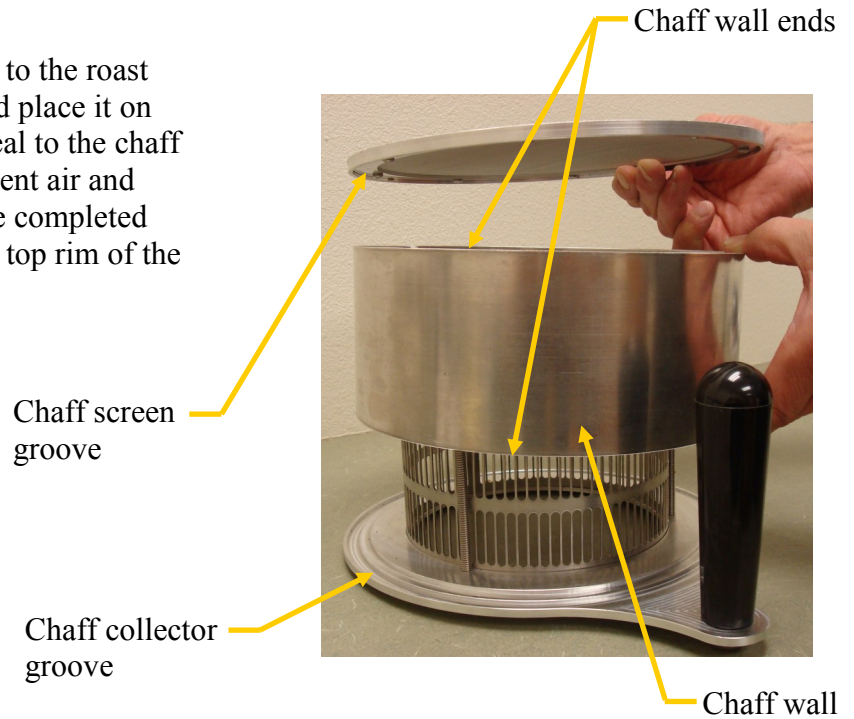

Completed roast chamber/chaff collector assembly.

Note: Use two hands when placing chaff collector assembly onto roast chamber.

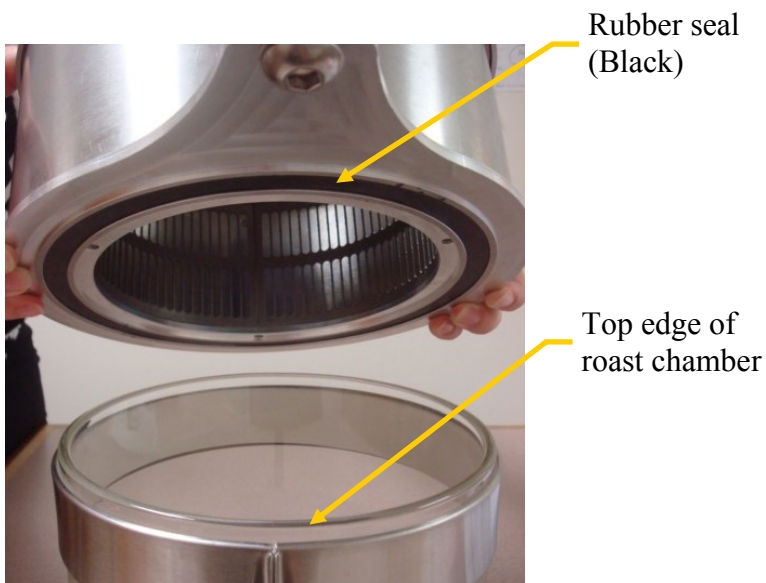

6. Control Board Functions

Roaster Controls: The roaster is controlled by an electronic control board that monitors the roasting process based on information provided by the temperature sensor (RTD) and allows the coffee to roast to a predetermined temperature based on the roast level setting selected by the user. The control board consists of the following user controls and display:

Power Switch	Controls the power to the appliance.
Gas switch	Activates the gas in stand-by mode. (Will not actively turn gas on.)
Down Arrow	Lowers the roast level with each press.
Up Arrow	Increases the roast level with each press.
LED Display	Displays current roast level setting. (Also provides time, temperature, and profile selection feedback as discussed in the hints and tips section.)

Initiate the roast with three simple steps:

1. Switch the power and gas switches to the **on** position.
2. Select the desired roast level for the coffee being roasted, using the up/down arrow buttons.
3. Push and release the start roast button.

Place the power and gas switches in the on position.



Select desired roast setting. (0-9)



Press the start roast button.
Roaster will start automatically.



6.1 Advanced Control Board Functions

The Sonofresco Advanced Definition Roasting Control Board can connect to an *optional* Sonofresco Roast Profile Development Software package via a blue Bluetooth enabled PC or MAC. Please contact Sonofresco regarding upgrade options for your roaster. By default, all six profiles contain the Sonofresco default ideal roast profile.

General operation

The Sonofresco Coffee Roaster Control Board is designed to operate independent of the Sonofresco Roast Profile Application. The profile software is not required for normal roaster operation, but the profile software is required for creation, editing, monitoring, and transfer of profiles to the roaster control. If your coffee roaster is ADR enabled, please refer to the following as a quick reference to get started. Please refer to the ADR software help file for detailed instructions in using the profile software.

Roast profiles

Six Roast profiles are stored within the roaster control memory, One Sonofresco Default (A), and five user defined profiles (B-F) (by default, all profiles are stored as the Sonofresco Default Profile).

Display

The control board incorporates a single display for reading both the current roast level setting (0-9) and the active roast profile (A-F). The display must be switched between the two modes in order to select the roast level and the active roast profile.

- **Selecting Profiles** Place the *power switch* in the on position.
 - Place the *gas switch* in the off position. (Fig. 2)
 - Press the *start roast* button, the display will switch to the currently active roast profile letter (A-F). (Fig. 3)
 - Select the desired roast profile letter using the *up/down* arrow buttons. (Fig. 4)
 - Press the *start roast* button, the display will switch back to the current roast level number (0-9).
 - Place the *gas switch* in the on position. (Fig. 2)
 - Change the roast level using the *up/down* arrow buttons to the desired roast level. (Fig. 5)
 - The roaster is now ready for a roast cycle and will do so utilizing the roast profile and roast level previously selected.
 - Press the *start roast* button to initiate a roast. (Fig. 6)



Fig. 2



Fig. 3

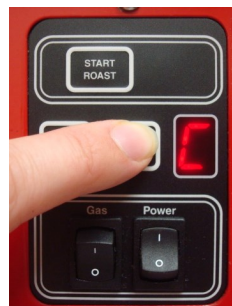

Fig. 4



Fig. 5



Fig. 6

7. The Roasting Process

Once the start button is pushed, the roaster will start roasting automatically and the following will be observed during the process:

- The blower will immediately turn on and the beans will bounce (fluidize) around in the roast chamber. The beans should appear to “swirl” or rotate around the roast chamber indicating that the beans are mixing properly.
- Approximately 5 seconds after the start button is pushed, a decimal point will come on in the lower right hand corner of the LED display indicating the control is cycling the gas on.
- At approximately 15 seconds after start, the gas will ignite indicated by a slight “puff” sound and heat in the roast chamber. **Note:** It is not uncommon for the inside of the roast chamber to look wet at the beginning of the roast cycle. This is simply condensation caused by moisture in the bean, will dissipate quickly, and will not affect the roaster performance.
- The roaster is now automatically roasting the coffee and will continue to cycle the gas on/off during the active roast cycle to gradually increase the bean temperature to the final roast level.
- During the roasting process, the beans will go through changes in color, size, and weight.
 - **Color:** As the bean temperature increases, the first noticeable difference is the darkening color from green to light brown and then to darker brown with oils on the bean surface if roasting on the higher roast levels.

Note: Decaffeinated coffee will have a brown color before roasting due to the decaffeination process.

- **Size:** As the bean is heated, the internal cell walls of the bean will expand from the heat and cause the bean to increase in size by nearly a third. This expanding of the bean is referred to as the “crack” and can be heard as a light snapping or cracking sound, typically occurring first around seven minutes and again near ten minutes (i.e. first crack and second crack).
- **Weight:** Before roasting begins, the bean is considered “heavy” or “green” due to the moisture trapped inside. During the roasting process the moisture is driven out of the bean. Towards the end of the roast the beans will appear to be bouncing around the roast chamber more rapidly due to the “weight loss” and increase surface area.
- At approximately eleven minutes, the beans will reach the final roast level temperature at which time the electronic control board will automatically cycle the gas off and enter the cool down cycle. During the cool down cycle, the blower continues to circulate air until the beans are cool enough to be handled (approximately seven minutes).
- After the cooling cycle is completed, the blower will shut down and the roaster will go into standby until the start roast button is again pressed.

8. Coffee Basics

Coffee Descriptions: We recommend reviewing our [Green Been Page](http://www.sonofresco.com) at www.sonofresco.com for brief descriptions for each of our single origin and Sonofresco blended coffees. Please let us know if you require additional information.

Roast Temperatures: It is important to understand that different varieties of green coffee beans, whether a single origin or blend, will roast differently from another at a given temperature. In fact, on occasion a current crop year bean will roast differently than a previous years crop due to various growing conditions from year to year.

The Sonofresco coffee roaster will roast a coffee to various end temperatures using roast levels incorporated in the control board. Each setting is incremented by 3.5°C per setting, starting at 193°C on level 0 and a maximum of 224.5°C on a level 9. Each end temperature is preprogrammed and cannot be modified by the user, but can be modified using the optional Sonofresco ADR software package. Please contact customer service for more information regarding the Sonofresco ADR software.

There are many factors that determine the perfect cup of coffee, such as bean type, quality, degree of roast, and the brewing process. It is our experience that customer geography also plays a large factor in determining the perfect cup of coffee. Not all coffee drinkers are created equal, some regions will want a bold dark coffee, while others will appreciate a lighter style coffee. It is important to experiment with different coffee beans, roast levels and brewing processes in order to determine what will best suit your customer base. Make it fun, involve your customers in the decision making process and you are sure to build a solid relationship with your customers.

Sonofresco recommends the following guideline as a starting point in developing your cup:

Use of coffee	Roast Level	End of Roast Temperature °C
Decafs, mild drips, breakfast blends	#4	207
Most drips, decaf espresso	#5	210.5
Espresso, robust drips (Italians, Yirgs, etc.)	#6	214

Handling Roasted Coffee

After the roasting and cooling process is completed, the beans can be placed directly into a bag or bin.

Freshly roasted coffee must be allowed to sit for 48 hours before grinding and brewing to allow the flavor to “develop.” This process, known as “degassing,” allows the gasses to escape as the flavors develop in the bean.

Proper handling should include allowing the beans to sit in a covered but **unsealed** bin before use. If the bin is sealed tightly, the gases cannot escape and the flavor development process will slow. Do not allow the beans to become wet or come into contact with syrups. It is also recommended to use the coffee within seven to ten days in an effort to maintain the freshest possible product.

9. Preparing for the Next Roast

After the last roast is completed, the roaster components will need to be cleaned prior to starting the next roast to ensure that each roast will be consistent with the previous batches. The following is a description of the fundamental operation and the maintenance required between roasts. The entire process should take no more than one minute to complete.

As discussed, the bean will expand and increase in size during the roasting process. During this expansion phase the bean will “crack” and shed it’s “skin” also known as chaff (the outer skin of the coffee bean). This chaff is captured by the fine mesh of the chaff screen to minimize the amount of particulate entering the ventilation system. The chaff also acts to balance the air flow in the system as the bean becomes lighter during the roast due to the moisture being driven off. The chaff screen is designed to catch the chaff but allow the hot roasting gases to pass through and into the ventilation system. Restricting the airflow through the screen, by not removing the chaff between roasts, will lead to darker and darker roasts. Additionally, oils from the beans are deposited on the wires of the screen during the roasting process and must be removed in order to minimize build up over time and cause a reduction in airflow through the screen.

The following maintenance summary will prevent the build up of oils on the screen. Detailed steps are outlined on the following page.

- Remove chaff collector from the roast chamber and set it upside down on a table.
- Vacuum chaff from the chaff collector.
- Remove the chaff collector and place on table right side up.
- Remove the balance of chaff from the chaff screen.
- Clean loose chaff from the chaff collector groove using wire brush.
- Clean inside and both ends of chaff wall with a dry terry cloth or paper towel to remove loose chaff.
- Clean the chaff screen with wire brush. (See chaff screen cleaning details.)

9. Preparing for the Next Roast (Continued)

- Remove the chaff collector from the roast chamber and set it upside down on a table.
- Remove the chaff from the chaff collector.



- Remove chaff collector and set on table right side up.
- Remove the balance of chaff from the chaff screen.



- Clean loose chaff from chaff collector groove using a wire brush.

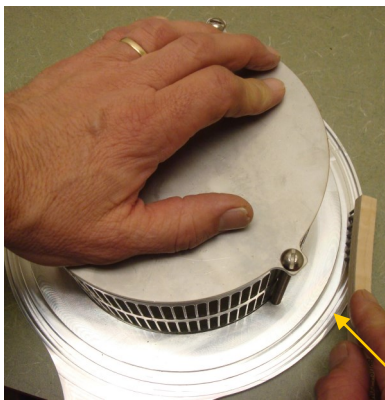

Chaff collector groove

- Clean inside and both ends of chaff wall with a dry terry cloth or paper towel to remove loose chaff and oils.



- Clean the chaff screen with a wire brush. (See chaff screen cleaning details on following page.)

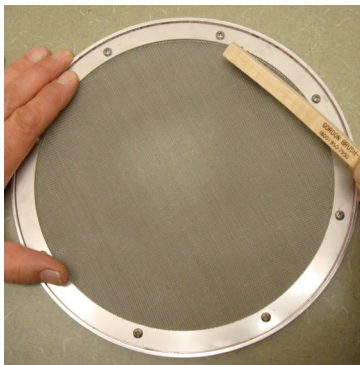

- Cleaned and reassembled the chaff collector assembly.



10. Detailed Chaff Screen Cleaning

The chaff screen consists of a wire mesh screen held in place by an aluminum outer ring. The mesh screen is simply wires woven together to create a wire grid. Each of these wires collect chaff and oil from the beans during the roasting process and must be cleaned to allow air to flow freely. A wire brush is used to clean the wires as well as the chaff screen groove (See detail below). Cleaning is accomplished by aggressively scrubbing both sides with a wire brush around the perimeter (outside edge) of the ring and then cleaning the wires in both directions.

- Clean chaff screen groove to prevent chaff build up. This buildup could affect the seal with the chaff wall.
- Clean the screen where it meets the groove around the entire perimeter of the screen.

Note: It is important that the screen is cleaned all the way to the outer edge where it meets the ring.

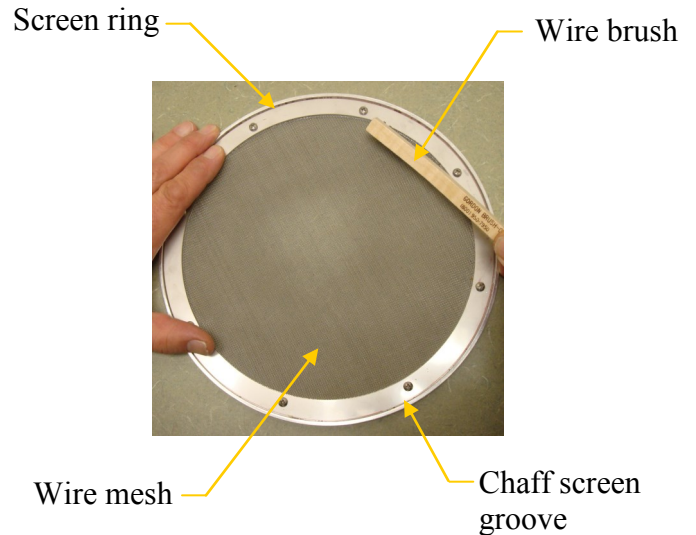

- Use the wire brush to scrub in the direction of the wires to ensure the entire surface of the screen is cleaned.

Note: A fine dust (dried oils from the beans) will be deposited on the table under the screen which indicates the cleaning is being done correctly.

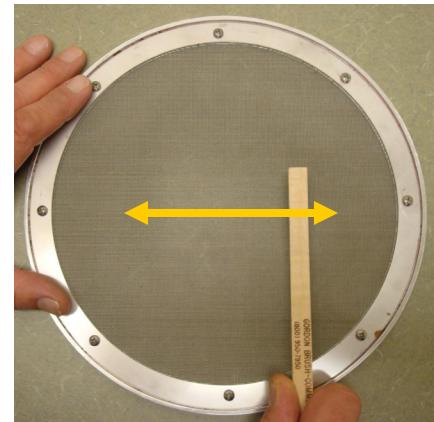

- Turn the brush 90 degrees to clean the wires going in the other direction.
- After completing the cleaning flip the screen over and repeat on the other side.
- Soak the screen in a commercial cleanser, such as Puro Caff©, weekly to remove excess oils.

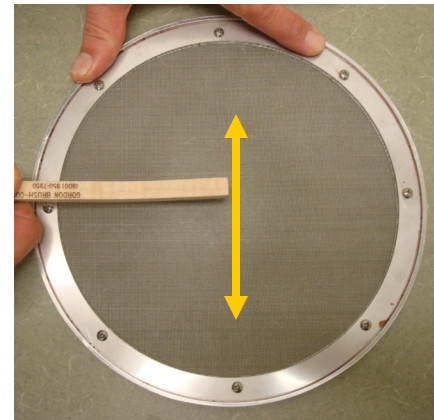

11. Roast Chamber Maintenance

It is important that the roast chamber be cleaned after every roast to prevent the build-up of oils on the glass surface as well as the bottom plate. Oil build-up is not only unsightly, it will also affect the roaster performance if the build-up becomes excessive. The beans must move around freely in the roast chamber to properly mix with hot air with the beans for an even and consistent roast. Oils deposited on the glass cylinder and bottom plate create a rough surface that can cause the beans to slow down in the roast chamber due to friction. This “slowing” of the beans can cause darker and inconsistent roasts. Wiping the roast chamber glass and bottom plate with a **dry** terry cloth or paper towel after every roast will reduce the build-up of oils.

Caution: The roast chamber is one of the more costly components of the roaster. Care must be taken when handling to prevent damage or breakage.

- With a firm grip on the roast chamber, wipe the entire inside surface of the roast chamber.
- To prevent breakage, avoid resting the roast chamber on a table or counter top during cleaning.



- With a firm grip on the roast chamber, wipe the bottom surface of the roast chamber.

Note: Some heat discoloration on the bottom plate is normal.



- At the end of the day, clean the entire roast chamber inside and out with a towel, warm water, and mild detergent to completely remove excess oils.

Note: It is not recommended that the roast chamber be soaked as this will affect the gaskets.

12. Daily Maintenance

Daily maintenance is important to keep the roaster operating and looking its best. A maintenance routine at the end of every roasting day will allow the roaster to be begin operation the next morning without delay.

- The daily maintenance includes:
- Clean the chaff collector assembly as you would in between roasts.
 - Clean the entire roast chamber inside and out with a towel, warm water, and mild detergent to completely remove excess oils.
 - Clean temperature sensor with a 3M pad (Scotchbrite®).
 - Clean smoke box assembly with a damp 3M pad (Scotchbrite®).
 - Clean external surfaces of the roaster, u-shape, chrome top etc., with a damp cloth and mild detergent.
 - Clean the area around the roaster to minimize the chaff build-up in the work area.

Temperature Sensor

The temperature sensor plays a critical role in the roaster's operation by measuring the current temperature of the beans and sending the information to the control board. The control board then interprets this information and cycles the gas on/off accordingly, thus ensuring that the beans roast evenly during the cycle following the 'Roast Profile'. If the temperature sensor sends inaccurate information to the control board, the outcome of the roasting process will likely be different than expected.

Example: The coffee beans are actively roasting at a temperature of 200°C (near the end of the active roast cycle), but the temperature sensor is only reading and sending a temperature of 195°C to the control board. The control board is designed to allow the beans to reach a set temperature at a given time, so the control board only seeing 195°C, continues to roast the beans. The beans at this point are near the end temperature, but are allowed to further roast creating a much darker than expected roasted coffee. Although the temperature sensor and control board are operating correctly, they are actually lagging behind the coffee's actual temperature. The most common reason for this is that the temperature sensor is being insulated from the heat of the beans due to excess build-up of chaff and oils. Similar to wearing a jacket in the winter, keeping the cold out and body heat in, but in the case, we are slowing down how fast the heat gets to the temperature sensor. Again, this "lag" causes the coffee to roast to a higher actual temperature than desired.

It is essential that the temperature sensor be maintained to ensure accurate measurement of the bean temperature for a successful outcome.

Component Maintenance

The two most important items to properly maintain are the screen and the temperature sensor.

The Sonofresco coffee roaster incorporates an improved hard mounted stainless steel temperature sensor which allows for more robust cleaning methods. The sensor will accumulate oils during the course of roasting, it is important to remove these oils on a daily basis to prevent excessive build up that can degrade the performance of the roaster. Clean the temperature sensor with a 3M® pad folded in half over the sensor. It is also acceptable to use a mild detergent, such as Clean-Rite® “Purple Power”, to break down tuff buildup. Rub the sensor back and forth as if you were sanding a pencil, the sensor should be cleaned down to the metal at the end of every roasting day.

- Fold the 3M® pad around the sensor.
- Rub the sensor back and forth to remove chaff and oil deposits.

3M® pad
(Scotchbrite)

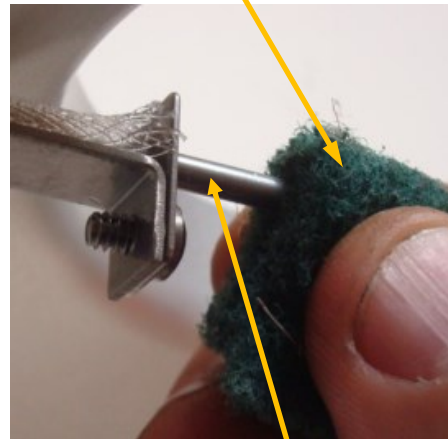
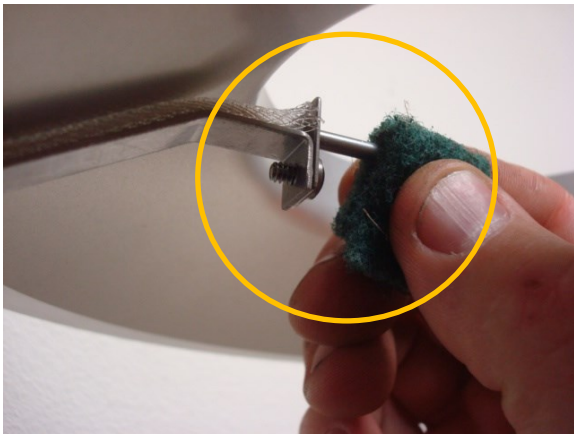

Temperature sensor
(RTD)

- Wipe the inside of the smoke box assembly using a Purple Power® dampened 3M® pad.
- The assembly should be cleaned down to the metal finish after every roasting day.

- Wipe the entire outside of the roaster with a cloth and mild detergent.
- Clean the chaff from around the roaster work area.



ROASTER MAINTENANCE SUMMARY

Schedule and follow these maintenance steps for trouble free roaster operation:

<u>Roaster Component</u>	<u>Maintenance Action</u>	<u>Frequency</u>	<u>Page</u>
Chaff Screen	<ul style="list-style-type: none">• Clean with wire brush• Soak in commercial cleanser	<ul style="list-style-type: none">• After every roast• Once week	18
Temperature Sensor	<ul style="list-style-type: none">• Clean sensor with a detergent dampened 3M pad (Scotchbrite)	<ul style="list-style-type: none">• Daily	21
Smoke Box Assembly	<ul style="list-style-type: none">• Clean surfaces with 3M pad (Scotchbrite)	<ul style="list-style-type: none">• Daily	21
Roast Chamber	<ul style="list-style-type: none">• Clean with soft cloth• Clean with warm water & mild detergent	<ul style="list-style-type: none">• After each roast• Daily	19
Chaff Collector	<ul style="list-style-type: none">• Clean chaff wall groove	<ul style="list-style-type: none">• After each roast	17
Outside Surfaces	<ul style="list-style-type: none">• Clean top panel and U-shape with mild commercial cleanser	<ul style="list-style-type: none">• Daily	21

13. Error Codes and Troubleshooting

The roaster employs five error codes, displayed on the control board LED display, to inform the user of potential issues with the operation of the roaster.

The roaster control board readout is a segmented single digit display, error codes are cycled to the display in series as follows:

An error code “E1” would be displayed as a backwards three or E, a pause, then the number one (1).

The code will continue to flash “E1”...”E1”...etc. until the power is cycled off and then on again. In the case of an “E1”, an out of range temperature sensor, the error will not clear unless the problem with the temperature sensor is resolved.

The most common errors are:

- “E2” - The roaster did not detect a rise in temperature during the start sequence, the most likely cause being a closed external fuel supply valve.
- “E4” - The temperature decrease during the active roast cycle when the temperature should be increasing. The most likely cause is the propane tank emptied during the roast process. In the event of an error code “E2” or “E4”, the control board will shutoff the gas supply and leave the blower running until the roaster is sufficiently cooled down.

However, an “E1” and “E5” error codes will result in both the gas as well as the blower to be turned off without entering the cool down cycle. In the event of an “E1” or “E5” error, the blower is turned off to avoid causing a fire in the roast chamber if the sensor cannot detect a proper temperature status.

When the blower is shut off, there is no longer cooling air available, so the following procedure should be followed to handle such a scenario:

- Remove roast chamber/chaff collector assembly from the roaster. **Caution:** The roast chamber assembly will be hot. Grasp **only** the roast chamber handle, and if possible, use oven mitts when removing the assembly from the roaster.
- Dump beans including the chaff assembly onto/into a non combustible area or receptacle. (Outside on pavement or in a metal sink would be considered a safe place.)

14. Troubleshooting

ERROR CODES

<u>Error Code</u>	<u>Symptom</u>	<u>Potential Cause</u>	<u>Solution</u>
E-1	<ul style="list-style-type: none"> Electronic control has detected an “out of range” condition on the temperature sensor. 	<ul style="list-style-type: none"> Broken wire, short in the wiring, or a defective temperature sensor. 	<ul style="list-style-type: none"> Replace temperature sensor.
E-2	<ul style="list-style-type: none"> Temperature sensor has not detected a sufficient increase in temperature. 	<ul style="list-style-type: none"> Problem with the gas supply. Dirty temperature sensor. Interference with airflow. 	<ul style="list-style-type: none"> Check gas shutoff valve or propane supply. See section on cleaning sensor. Clean screen, check exhaust, use correct amount of beans.
E-3	<ul style="list-style-type: none"> The roast did not reach its set point in twenty minutes. 	<ul style="list-style-type: none"> Lack of proper Gas supply. Dirty temperature sensor. 	<ul style="list-style-type: none"> Check shut off valve. Check gas supply pressure. Clean temperature sensor.
E-4	<ul style="list-style-type: none"> Failure to achieve ignition later in the roast cycle. 	<ul style="list-style-type: none"> Likely cause is the propane supply ran out. Gas supply is shut off after roaster has started. 	<ul style="list-style-type: none"> Refill propane tank. Open gas shutoff valve.
E-5	<ul style="list-style-type: none"> Temperature rises after the end of the roast cycle. May indicate a presence of fire. 	<ul style="list-style-type: none"> Overfilling the roast chamber. Neglecting to clean the chaff screen , chaff collector, and temperature sensor. 	<ul style="list-style-type: none"> Use recommended amount of beans. Clean chaff collector and screen after each roast.

15. If You Need Help

If you have done your best to work out a problem or question, and still are not able to solve it, we will be glad to help. Call us at (360) 757-2800 or contact us by email at office@Sonofresco.com.

16. Replacement Parts

A number of replacement parts are available through Sonofresco, including new roasting chambers, new chaff collector screens, temperature sensors, control boards and other items. You may want to have spare screens or roasting chambers on hand to avoid interruptions in production. Contact your local representative or the Sonofresco office for prices and availability.

17. Hints and Tips

Roast Profile: One way to further understand and monitor the roaster operation is by viewing the roast profile. The electronic control board is designed to control the rate at which the coffee temperature rises over time. The roast profile is basically a time versus temperature graph that determines when the gas is cycled on to heat the beans and then cycled off to prevent the beans from heating too quickly. The gas is cycled on and off throughout the entire active roasting process. The roaster will continue along the roast profile until the temperature reaches the specified temperature associated with the roast level setting and then enters the cool down phase. The elapsed time and current roast temperature can be viewed, during the active roast, via the LED display and referenced to the roast profile graph on the following page. *Real time data can be viewed using the Sonofresco ADR software, call for details.*

Time Measurement:

The time measurement is the time from the beginning of the roasting process when the start roast button was pressed.

- During an active roast, push and release the start roast button to display the time.

The roaster control board readout is a segmented single digit display, numbers are cycled to the display in series as follows:

Example: The roaster is running for 1:30 (one minute and thirty seconds) from start and the roast button is pressed and released the display will scroll 1...-...3...0. (one...dash...three...zero.) This time should be mentally noted; immediately proceed to read the temperature data.

Temperature Measurement:

The temperature measurement is the real time temperature of the roasting process at the moment it is viewed.

- During an active roast, simultaneously push and hold both the up and down arrows to display the temperature. **Note:** If the up and down arrow buttons are continuously held down during the entire roast process, the temperature can be viewed rising over the course of the active roast.

The roaster control board readout is a segmented single digit display, numbers are cycled to the display in series as follows:

Example: The bean temperature is currently 135°C (one hundred thirty five degrees Celsius); the display will scroll 1...3...5. This temperature should be mentally noted and compared to the graph on the following page.

Temperature Measurement:

Graph Comparison: Simply find the time on the bottom edge of the graph and the temperature on the left side and intersect to find the current position on the roast profile. Although this data is not critical when roasting coffee, you may be asked to perform this information during a service call to help troubleshoot potential roaster issues. The Sonofresco roast profile is located on the following page.

SONOFRESKO COFFEE ROASTER ROAST TEMPERATURE PROFILE

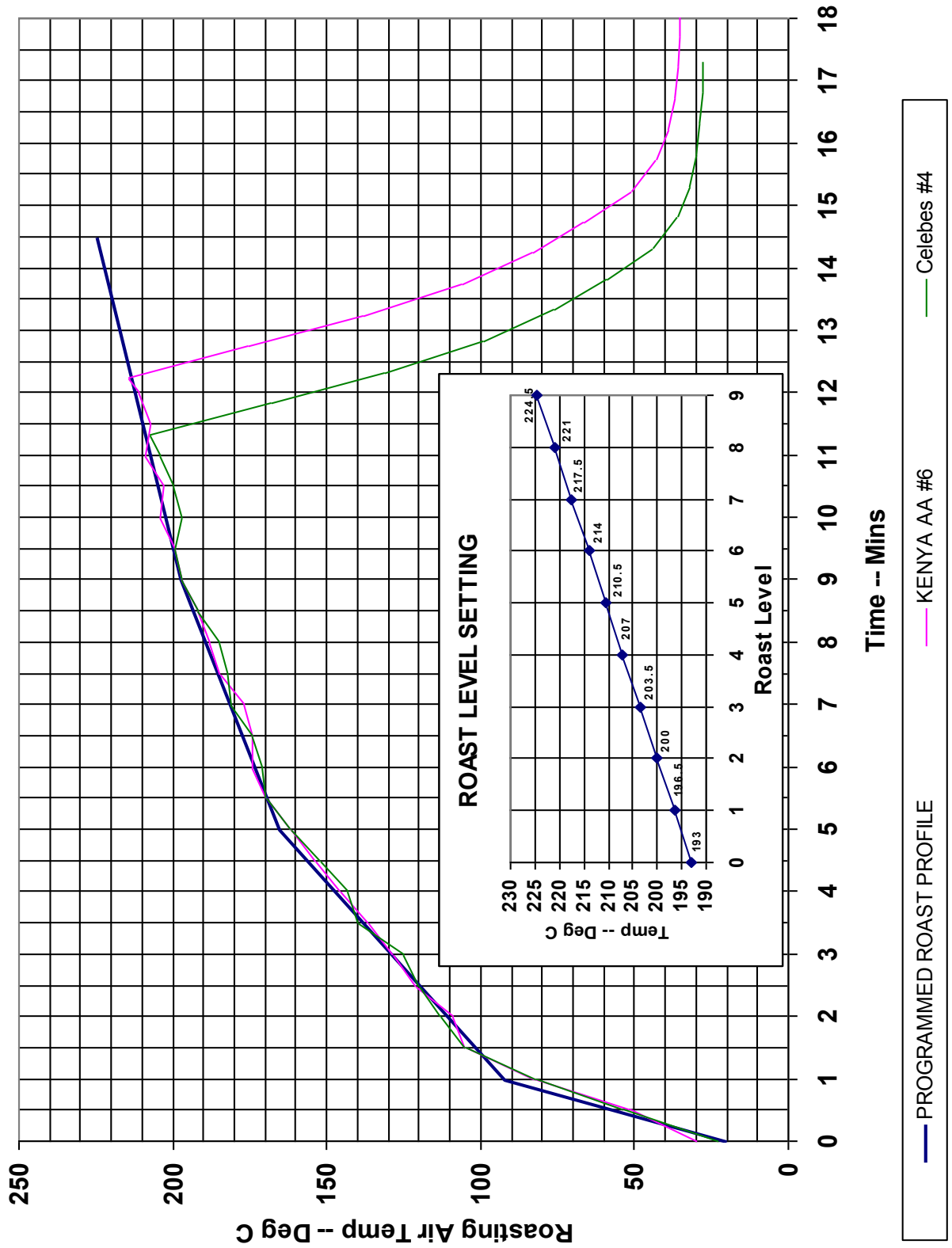

18. Warranty

Coffee Kinetics, LLC guarantees to the original purchaser that the Sonofresco product is free from defects in material and workmanship for a period of 1 year (12 months) from the date of purchase.

In the event of any defects in material or workmanship, Coffee Kinetics, LLC's sole liability shall be to repair or replace the defective product or components, at its sole discretion.

- If the product is determined to be defective, Sonofresco will repair or replace the product free of charge.
- This warranty does not cover replacement of the glass roasting chamber, the chaff screen, or gaskets worn or damaged during the normal course of use.
- This warranty does not cover problems resulting from poor installation or operator abuse. Roasting anything other than green coffee beans in the appliance will void the warranty.
- Repair or replacement as provided under this warranty is the exclusive remedy of the purchaser. Sonofresco shall not be liable for any incidental or consequential damages for breach of any express or implied warranty on this product.
- Advanced return authorization is required from our Customer Service Department (866-271-7666). If return is required, please contact Customer Service for a Return Authorization Number. Products received without return authorization will not be accepted.
- This warranty does not apply to any product that has been altered, misused, neglected, or which has been used other than the purpose stated in the furnished owners manual.

Please contact Coffee Kinetics Customer Service Department with any questions:

1365 Pacific Drive
Burlington, WA 98233-3128
866-271-7666
office@sonofresco.com

19. Return Policy

There are a few important things to keep in mind when returning a product you purchased from the Coffee Kinetics, LLC:

- You have 30 calendar days to return an item from the date you received it.
- Only items that have been purchased directly from Coffee Kinetics, LLC, can be returned to Coffee Kinetics, LLC. Products purchased through an authorized distributor must be returned to the same distributor in accordance with their respective returns and refunds policy.

- Please ensure that the item you are returning is repackaged using the Sonofresco approved packaging with all the cords, adapters, and documentation that were included when you received it.

There are some items, however, that are ineligible for return, including:

- Custom products, including color
- Green Coffee
- Coffee Packaging

Once we receive your item, a refund is initiated immediately after inspection* of returned item. The way your refund is processed depends on your original payment method:

§ If you paid by credit or debit card, refunds will be sent to the card-issuing bank within five business days of receipt and inspection* of the returned item. Please contact the card-issuing bank with questions about when the credit will be posted to your account.

§ If you paid by check or money order, refunds will be issued by check and sent via USPS to the ship to address on the original invoice within five business days of receipt and inspection* of the returned item.

§ If you paid by wire transfer, refunds will be issued by check and sent via USPS to the ship to address on the original invoice within five business days of receipt and inspection * of the returned item.

* Incoming inspection process could take up to 5 days

How To Return an Item

Your item must be in its original unused condition to be returned, unless there is a manufacturer defect. You must return the item **within 30 days** of your purchase.

1. Please email office@sonofresco.com to request a refund and we will assign you a RMA #*.
2. Ship your returned item to:
Coffee Kinetics
Department RMA #
1365 Pacific Drive
Burlington, WA 98233
3. Merchandise that has been worn, used, or altered will not be accepted for return or exchange.

*Items will not be received without a RMA # (Returned Material Authorization Number).

Restocking Fee

All items are subject to a 15% restocking fee, this will be deducted from your refund. We also do not refund the original shipping and handling costs, import duties that you paid on the order. Customers returning products are responsible for return shipping costs, import duties, and taxes.

20. Specifications

There are four models of the Sonofresco coffee roaster. The roasters all follow the same roast profile, and have the same 2.8 pound (green) per cycle roasting capacity. All of the machines will use about 350 watts of electric power. The heating in all machines is supplied by either propane or natural gas. The Sonofresco models:

Models	Fuel	Voltage	Amperage	Watts	Input Rating
2100	Propane	120vac/60 Hz	3 amp	360	45,000 BTU/hr.
2200	Natural Gas	120vac/60 Hz	3 amp	360	48,000 BTU/hr.
2300	Propane	230vac/50 Hz	3 amp	345	45,000 BTU/hr.
2400	Natural Gas	230vac/50 Hz	3 amp	345	48,000 BTU/hr.

Units intended for 50 Hz will not operate properly on 60 Hz and vice versa. Units intended for natural gas will not operate properly if run on propane. Units intended for propane will not operate properly on natural gas. Please contact Sonofresco for information regarding converting a roaster from one fuel to another. Roasters cannot be field converted without a fuel conversion kit specific to the Sonofresco coffee roaster.

Any attempt to convert without the proper conversion kit could result in injury or death.

All models weigh approximately 55 pounds (25 kilos), and are 15 inches (28.6 cm) by 21-3/4 inches (48.3 cm) by 29 inches (68.6 cm) high.

Models 2100 and 2200 are designed and tested for use in the U.S. and Canada to the following standards:

Gas-Fired Food Service Equipment In accordance with:
American National Standards Institute ANSI Z83.11b - 2009
Canadian Gas Association CGA 1.8b - 2009
NSF/ANSI 4 - 2009

Coffee Kinetics, LLC 1365 Pacific Dr. Burlington, WA 98233 (360)757-2800 (360)757-8172 Fax
www.sonofresco.com